

PC-BOT 914 Complete Wiring Block Diagram

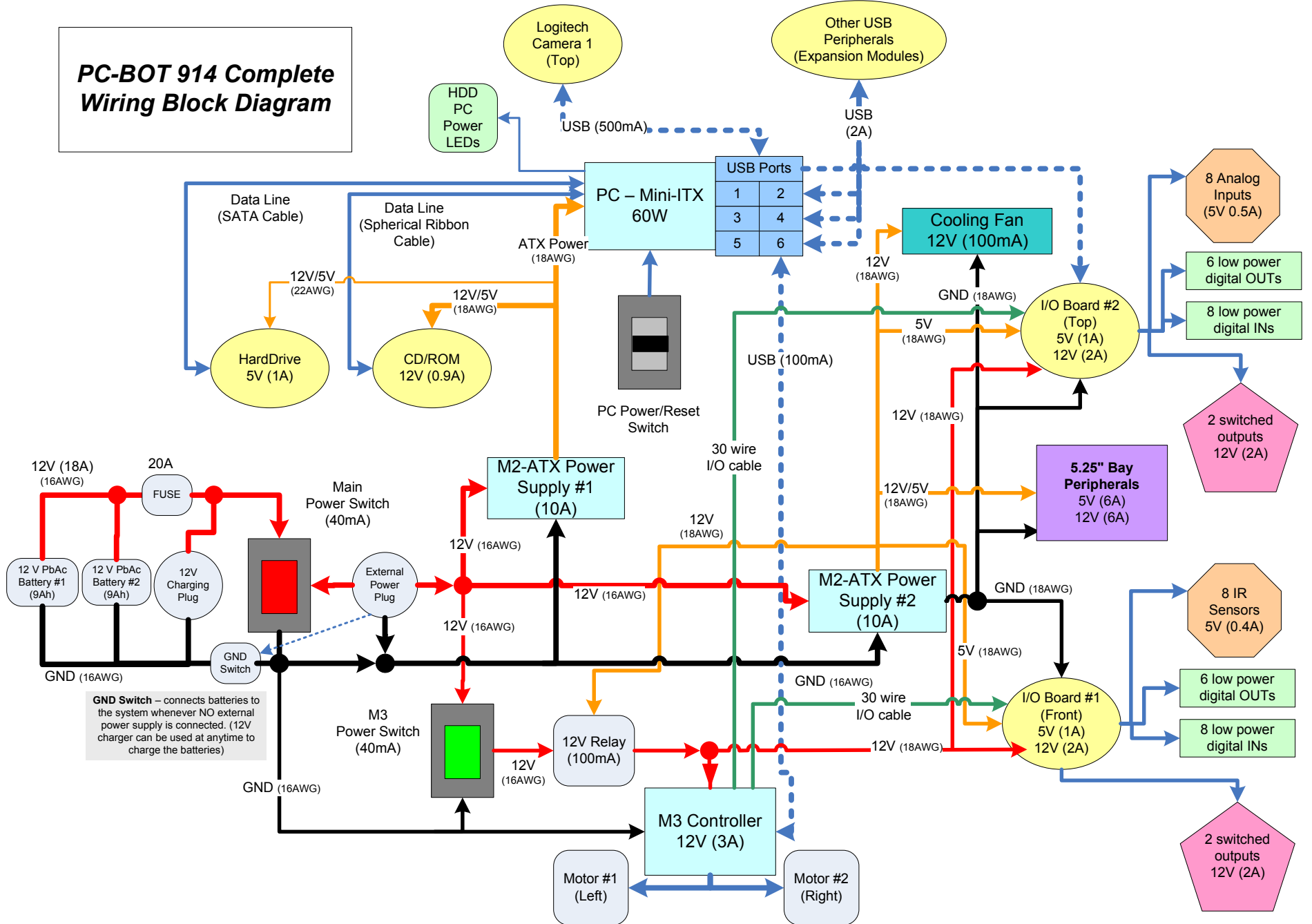

GND Switch – connects batteries to the system whenever NO external power supply is connected. (12V charger can be used at anytime to charge the batteries)

Note: Specifications may change without notice

Document Id:	
Description: PC-BOT 914 Complete Wiring Block Diagram	
Revision: v1.1	Date: Sep 26, 2006



PC-BOT 914 Wiring Diagram for how the External Power Plug and 12V Charger Plug are used in the system

Charging Plug (CHG)
 Is used to safely charge the batteries using the Intelligent Soneil Charger with a maximum current of 3A

External Power Plug (EXT)
 Is used to power the entire robot (including motors and sensors) continuously. This allows the user to leave the robot turned on indefinitely. **ONLY** the recommended external power supply should be used. The external power supply will/should not charge the batteries.

Using both the charger and the external power supply
 When an external power supply is plugged into the External Power Plug, the batteries and charger connection is switched off the main line. This is done to protect the batteries from being overcharged by the external power supply. The charger will continue to replenish the batteries in this state but will no longer feed the robot power.

SEE THE CHART ON THE NEXT PAGE

Connection Safety
 The robot has been designed so that the charger and the recommended external power supply can be plugged into either plug **WITHOUT** damaging the robot. Although the plugs look the same, they are not.

Either way, the user should make an effort to connect the devices in their appropriate plugs.

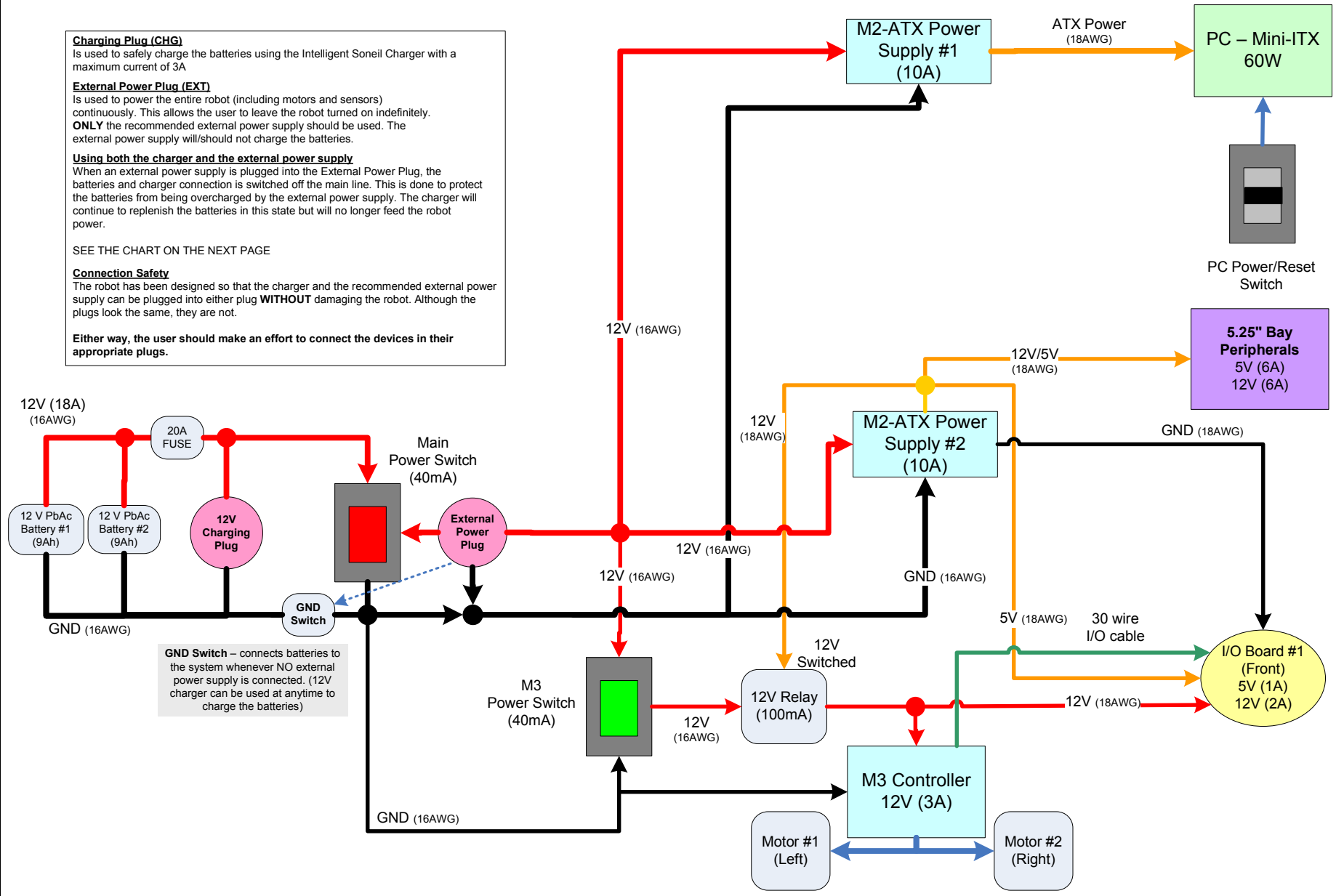

Note: Specifications may change without notice

Document Id:	
Description: PC-BOT 914 CHG/EXT Wiring Block Diagram	
Revision: v1.1	Date: Sep 26, 2006



PC-BOT 914 Wiring Diagram for how the External Power Plug and 12V Charger Plug are used in the system

Using the BATTERY CHARGER		
<i>Connected to Plug:</i>		
Main Switch	CHG Plug	EXT Plug
ON	Slows down battery discharge and powers the robot	Slows down battery discharge and powers the robot
OFF	Charges battery	No effect
Using the RECOMMENDED EXTERNAL POWER SUPPLY		
<i>Connected to Plug:</i>		
Main Switch	CHG Plug	EXT Plug
ON	No effect	Powers the robot indefinitely
OFF	No effect	Powers the robot indefinitely

PC-BOT Run Time: (note: the times listed are estimates)

Autonomous movement, Charger NOT connected	2 hours
No Autonomous movement, Charger NOT connected	4-5 hours
No Autonomous movement, Charger IS connected	8-9 hours
No Autonomous movement, Ext Power supply connected	Continuous

Battery Charge Time
2 hours to recharge batteries from auto-shutoff point

Note: Specifications may change without notice

Document Id:	
Description: PC-BOT 914 CHG/EXT Connection Chart	
Revision: v1.1	Date: Sep 26, 2006



PC-BOT 914 Power Budget

Note: Batteries currently used in the PC-Bot are 12V 18Ah capacity. Maximum current drawn should not exceed 18A (216W). (This will be fuse limited). The values listed below are max current drawn for the given item, the total of which goes well beyond the maximum allowed current. Some combination of the following, adding up to under 216W, can be used in the system.

Total System Power			
Item	Quantity	Maximum Current/Voltage (From the Batteries)	Total Wattage
M2-ATX Power Supply (For PC)	1	12V~7.67A (92W)	92W
M2-ATX Power Supply (For Peripherals)	1	12V~9.88A (118.6W)	118W
M3 Controller	1	12V~3A (36W)	36W
I/O Board - Switched 12V Outputs (Headlights, etc.)	2	12V~2A (24W)	48W
Main Power Lighted Switch	1	12V~0.04A (0.6W)	0.6W
M3 Power Lighted Switch	1	12V~0.04A (0.6W)	0.6W
		Total Possible:	295.2W
		Total Allowed:	216W

Note: More detailed view of M2-ATX Power Supplies shown below:

M2-ATX Power Supply (For PC)		
Item	Quantity	Maximum Current/Voltage (Drawn by the item)
Mini-ITX	1	60W
HDD (40Gig)	1	5V~1A (5W)
CD/DVD ROM	1	12V~0.9A (12W)
USB Web Camera	2	5V~1A (5W)
Other USB Peripherals	4	5V~2A (10W)
	Total Possible:	92W

M2-ATX Power Supply (For Peripherals)		
Item	Quantity	Maximum Current/Voltage (Drawn by the item)
M3 Cooling Fan	1	12V~0.12A (1W)
Top I/O Board - Sensors/Analog/Digital IN-OUT ONLY	1	12V~0.6A (7.1W)
5.25" Bay Peripherals	6	5V~6A, 12V~6A (102W)
Front I/O Board - Sensors/Analog/Digital IN-OUT ONLY	1	12V~0.6A (7.1W)
Relay for M3 and I/O 12V outputs	1	12V~0.117A (1.4W)
	Total Possible:	118.6W

Note: More detailed view of the I/O board shown below:

I/O Board - Sensors/Analog/Digital IN-OUT ONLY		
Item	Quantity	Maximum Current/Voltage (Drawn by the item)
IR (Analog) Sensors	8	5V~0.4A (2W)
5V low power switched outputs	3	5V~0.9A (4.5W)
Digital outputs	3	5V~0.12A (0.6W)
	Total Possible:	7.1W

Note: Specifications may change without notice

Document Id:	
Description: PC-BOT 914 Power Budget	
Revision: v1.1	Date: Sep 26, 2006



**PC-BOT 914 Maximum (Worst Case Scenario) Current/
Voltage Usage over time**

Current/Voltage Discharge on PC-BOT

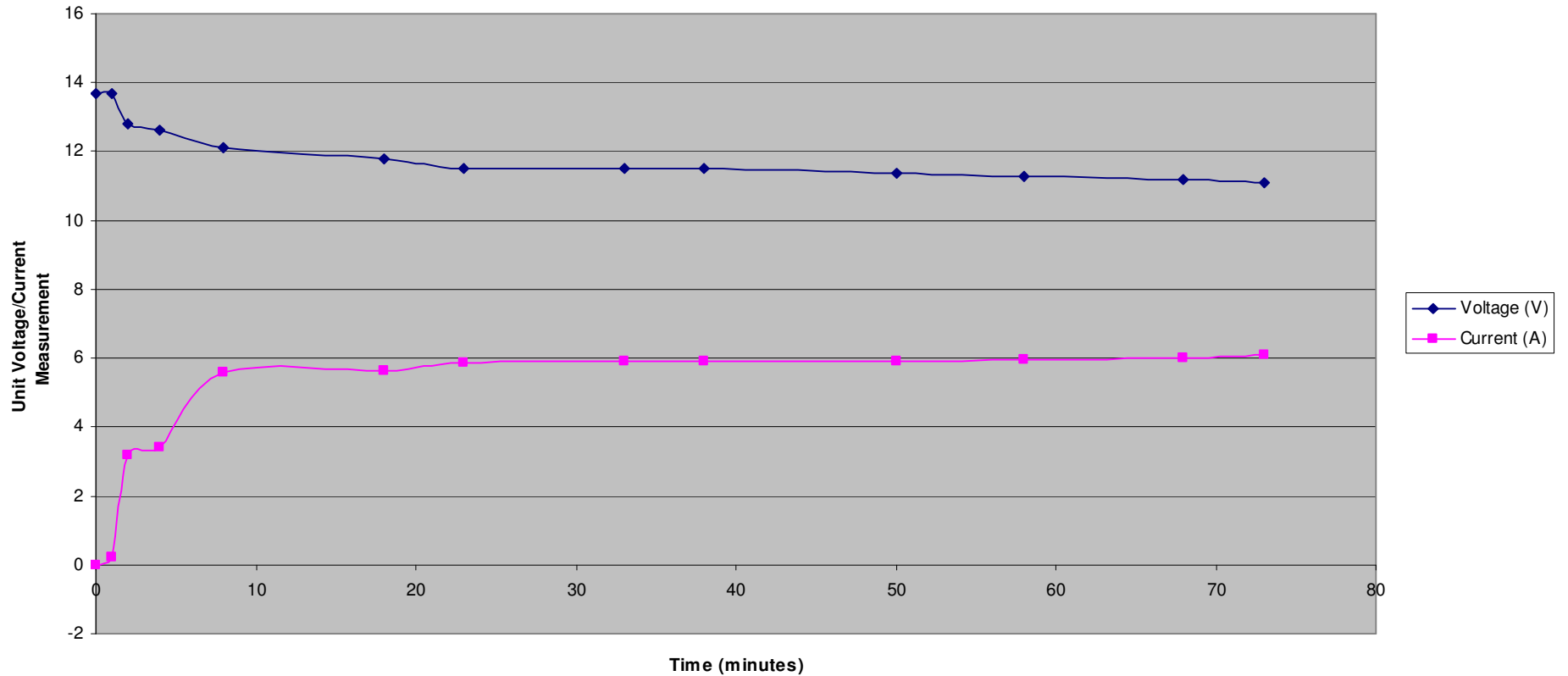

Details	Time	Voltage	Current
Robot Power Turned OFF	0	13.7	0
Main Power Switch ON	1	13.7	0.22
PC Booting up	2	12.8	3.2
Windows started	4	12.6	3.4
Brian GUI started, headlights turned ON, motors moving with full torque (100% duty cycle), USB web camera and wireless device running.	8	12.1	5.6
Continuous Movement	18	11.8	5.63
Continuous Movement	23	11.5	5.85
Continuous Movement	33	11.5	5.9
Continuous Movement	38	11.5	5.9
Continuous Movement	50	11.35	5.9
Continuous Movement	58	11.3	5.97
Continuous Movement	68	11.2	6
Auto-Shutoff	73	11.1	6.1

This chart indicates worst case scenario current discharge of the PC-Bot. The motors were run at full torque (100% duty cycle), all sensors, USB peripherals (camera, wireless network and mouse) and headlights were turned ON. The movement was continuous at low speed which leads to maximum current drain.

Note: Specifications may change without notice

Document Id:
 Description: PC-BOT 914 Maximum Current/Voltage Usage
 Revision: v1.1 Date: Sep 26, 2006

